

BM-2000

Fully automatic encasement machine Introduction Manual

Performance characteristics

1. The packaging has a wide range of applications and can be matched with any packaging production line.
2. Capture two packages at once, high work efficiency.
3. Dual mode operation mode, more flexible.
4. High degree of intelligence, using robots to grab and pack boxes.
5. Convenient operation and easy replacement of different specifications.
6. The electrical control box and pneumatic control box of the equipment adopt IP44 level.
7. It is relatively easy to maintain and repair, with a simple working principle and structure.

Equipment sample drawing

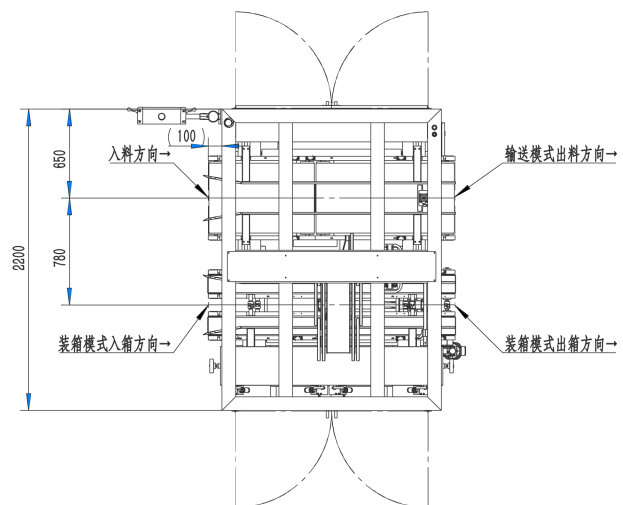
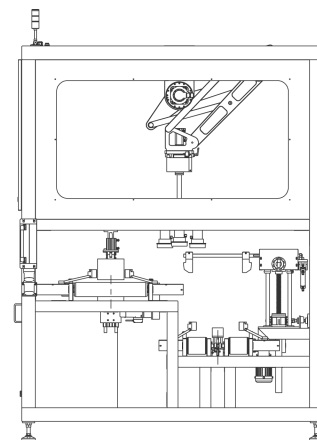
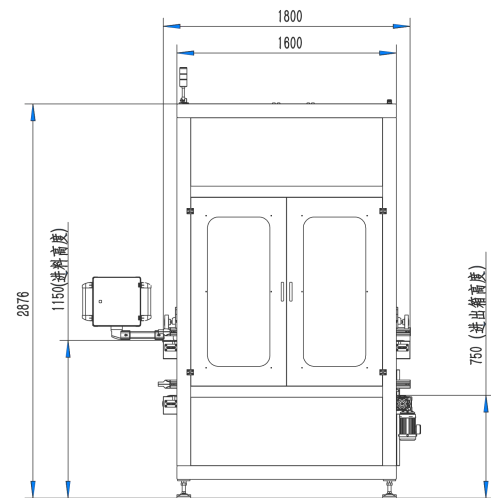

Equipment parameters

Number	Name	Technical Parameters
1	Packing Range	Flat shape 2.5-10 kg ; Brick shape 2.5-5kg
2	Packing speed	1100 bags/hour
3	Power Supply	AC380 Three-phase Five-wire System, 4KW
4	Air Consumption	0.6MPa, 0.2m ³ /min
5	Working Temperature	-10-40°C, Relative Humidity: < 90%
6	Equipment Dimensions(LxWxH)	1553*2465*2590.5mm
7	Matreial Conveyor Height	1000mm
8	Carton Conveyor Height	600mm

Color diagram of the equipment (subject to the actual product)



Configuration list

Serial Number	Product Name	Brand
1	PLC	Inovance
2	Contactora	Schneider (France)
3	Servo Motor	Inovance
4	Cylinder	AirTAC (Taiwan)
5	Solenoid Valve	Mindman (Taiwan)
6	Terminal Block	Weidmüller (Germany)
7	Relay	Schneider (France)
8	Photoelectric Switch	Omron (Japan)/Autonics (Korea)
9	Gear Motor	GPG(Zhejiang)
10	Suction Cup	Piab (Sweden)
11	Sponge Suction Cup	WMECA

List of vulnerable and consumable parts

Serial Number	Name	Model/Specification	Quantity/Year	Illustration/Notes
1	Suction Cup	G.BGI48-2S50.B3.S1.G38M.01	12 pieces	
2	Sponge Suction Cup	VACW-TVG130x220	2 pieces	
3	Linear Bearing	LMK20UU	4 pieces	
4	Cylinder Seal Ring	ACQ32	2 sets	
5	Bearing	FL001	2 pieces	
6	Stainless Steel Spring	1.5x25x90 (wire diameter x OD x height)	4 pieces	
7	Linear Bearing	LMH10UU	2 pieces	
8	Vacuum Generator	ABM20	6 pieces	
9	Floating Joint	F-M14x150F	2 pieces	
10	Swing Rod 1	Self-made	2 pieces	
11	Swing Rod 2	Self-made	2 pieces	
12	Swing Rod 3	Self-made	2 pieces	